

berbel



ENGLISH VERSION

→ Extraction System Collection

Indulge yourself:
Never settle for anything less than the very best.



berbel product world

Hob extractor fans & hobs

Hob extractor fans

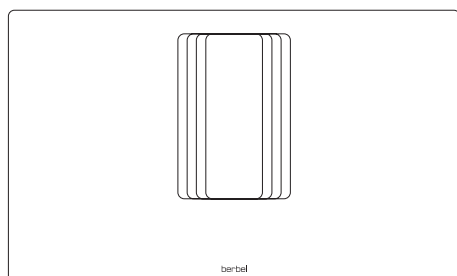

Downline Infinity → 17

→ 18 Downline Performance

Downline Compact → 19

Hobs

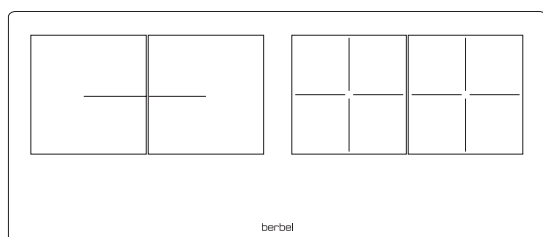

→ 23 Panorama Performance

Extractor hoods

Skyline island hoods



→ 27 Skyline Frame

Skyline Edge Play → 28

Skyline Edge Base → 32

Skyline Edge Sound → 34

Skyline Edge Light → 35

Skyline Curve → 36

Skyline Round → 37



berbel product world

Extractor hoods

■ Headroom hoods

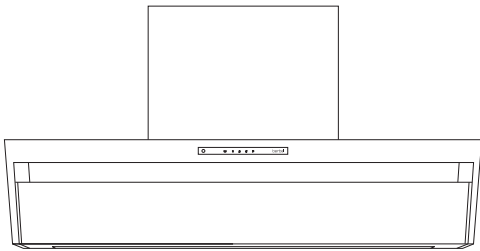

Ergoline 2 → Ergoline Base 43

→ **44 Formline**

Glassline → 46

Smartline → 47

■ Island hoods

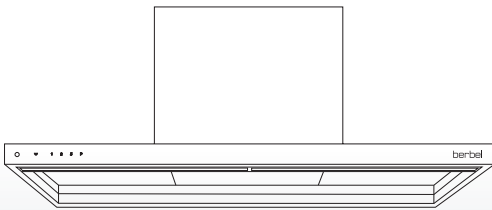

Ergoline → 51

→ **52 Glassline**

Blockline → 54

Smartline → 55

■ Wall-mounted hoods

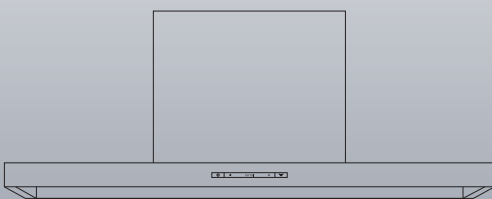

Glassline → 61

Blockline → 62

→ **63 Smartline**

Extractor hoods

■ Built-in hoods & fan units

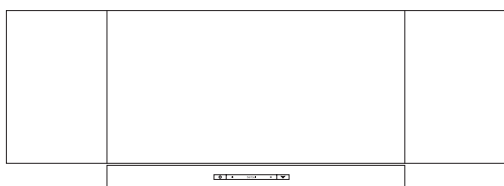

Glassline → 67

Firstline Touch → 68

→ **69 Firstline**

Firstline Unseen → 70

Fan unit Firstline → 71

Accessories

■ Exhaust air → 73

■ Recirculation | permalyt® → 75

■ EcoSwitch → 77

Features

■ Overview of models → 80

berbel service

■ Customer service → 86



berbel is ...

UNIQUE

The unique berbel principle relies on **centrifugal force**. The result: lastingly efficient extraction systems – without performance-reducing fat filters.

WHISPER-QUIET

Energy-efficient and quiet **EC fan motors** and resistance-free air routing without performance-inhibiting fat filters ensure pleasant, long-lasting and smooth running.

EFFECTIVE

Curry, fish, or stew – berbel combats them all. **Recirculation filters** with a particularly large surface for certified odour trapping of up to 97 percent.

CLEAN

berbel extraction products are easy to clean, ensuring an outstanding level of hygiene in any kitchen. Simply open the **collection tray**, wipe it out, and it's clean!

AWARD-WINNING

Products by berbel receive awards for their innovativeness, as well as for their functional and extraordinary **product design**.

MADE IN GERMANY

berbel products are developed, tested, assembled and boxed in **Germany** and exported across the world. berbel uses only the best materials and meets the highest quality standards.



berbel location in Germany



The berbel principle



The berbel principle

The 3 COMPONENTS of the berbel principle:

- ① Cooking and frying vapours are sucked in through a narrow gap.
- ② The air is then sped up as it enters the system and is pushed through two bends. The resulting centrifugal forces expel the fat particles from the air effectively and at a low noise level. This means that they are separated from the air rather than filtered. Fat is therefore collected in the extraction system with long-term efficiency in the first step, and air can continue to flow without hindrance.
- ③ The final separator in the middle captures even the smallest particles. It is easy to remove and can be cleaned in the dishwasher.

The result: consistently high levels of fat separation. Quite simply an impressive principle.





Simply swing it out, wipe it, and it's clean!

The unique berbel principle is based on innovative technology: centrifugal force cleans the air enduringly and reliably. Whether you're planning to serve seared steaks, a hearty stew or penne with pesto, all the fats and oils are collected directly in the collection tray.

So you can simply swing it out, wipe it, and relax. Unhygienic fat filters that require elaborate cleaning and affect the extraction system's long-term performance are a thing of the past.









Downline hob extractor fans

Our Downline hob extractor fans are especially popular for open-plan kitchens. Integrated into a state-of-the-art induction hob, they represent a double act of innovative technology. In addition, they provide for unobstructed views, allowing you to enjoy cooking with your family and friends.

The hob extractors fans are available in three different versions. The entry-level "Compact" model offers a clear selection of useful functions. For those who cannot resist a wide range of hob functions and a moveable Powermover, the fully equipped "Performance" model is the right choice. The absolute highlight among the hob extractor fans is the Downline Infinity with a particularly large induction hob that promises carefree cooking pleasure and is full of extras.





Downline Infinity hob extractor fan

A hob with innovative dimensions

The extra-large **Downline Infinity** induction hob makes cooking into a real experience. The main functions can be controlled intuitively on the hob itself or via elegant rotary knobs. The hob extraction system absorbs cooking and frying vapours, and the special printing technique reduces the noise caused by cookware being moved around on the hob. The extractor hood doesn't simply do its job, it triumphs!



Downline Performance hob extractor fan



A powerful ventilation concept

The combination of a powerful hob extraction system and a modern induction hob is the basis for the **Downline Performance's** first-class performance. A wide range of functions allow it to be set up individually for diverse cooking situations. Thanks to the movable Powermover, rising cooking and frying vapours are captured optimally and are quickly and effectively eliminated. After cooking, all parts that come into contact with fats can be removed easily and cleaned conveniently in a dishwasher.



Downline Compact hob extractor fan

Pure cooking enjoyment

The **Downline Compact**, berbel's entry-level hob extraction system, offers four generously sized cooking zones which are controlled via an amber-coloured control panel. Thanks to the innovative berbel principle and the single-piece inflow grid, cooking and frying vapours are always captured optimally – as reliably after several years as on the very first day. The separator unit is easily accessible and ensures easy cleaning.





Hobs

Thanks to the fact that the cooking zones are arranged in a row, the innovative panorama hob offers more space while cooking, and there is no need to reach across any hot, steaming pots. Unobstructed access to all pots and pans is complemented by the integrated extraction system control feature. You don't need to adjust your extraction system, and this means that your hands are free for creative cooking.

The fan is controlled via a slider on the elegant white control panel. There are five of these in total, one for the extraction system and one for each of the four cooking zones. berbel calls this function AutoRun+



Panorama Performance induction hob

Top comfort and functionality

The **panorama induction** hob has a host of practical features and allows the extractor hood to be controlled directly on the hob. The four generously sized cooking zones and the berbel fan can be controlled using sliders on the elegant white control panel. Pots and pans glide over the high-quality surface so easily that they almost seem to move of their own accord.





Skyline island hoods

Smooth effect lighting turns the Skyline island hood into your personal design highlight. Light colours ranging from bright cool tones through to understated warmer shades, allow for the hood to be integrated into modern kitchens most exquisitely. It floats down incredibly discretely to reach the ideal height to capture cooking vapours produced on the hob.

If you do not need it, it rests unobtrusively below the ceiling. The Skyline island hood is at your service at the push of a button. It always knows exactly where it is, thanks to its teach function. The hood relies on the berbel principle to ensure plenty of headroom and clean air.



Skyline Frame island hood

A design with two variants

In addition to its role as an extraction system, the **Skyline Frame** is also a functional, multi-variant lighting object. Its effect lighting can be configured individually from a cool blue to warm coppery tones, creating a beautiful highlight for any kitchen. Finished with a slim, matt black tube frame, the Skyline Frame is distinguished by its urban flair and modern loft look, with or without the shelf units on the side.



Skyline Edge Play island hood



Comfort without limits

The new **Skyline Edge Play** island hood impresses with a range of functions that take the cooking experience to an exciting level. The innovative gesture control enables easy control of the lift setting, light and fan control with simple hand movements, without needing to touch the hood. The unique berbel Motion-Lights create special moments. All functions can also be conveniently controlled via the berbel+ app. A comfortable experience without limits.





Skyline Edge Play Motion-Lights



Fascinating atmosphere created by berbel Motion-Lights. The berbel Motion-Lights bring a very special lighting atmosphere to the kitchen. With a choice of up to 12 light sequences, they offer a variety of soft colour transitions, dynamic lighting effects and calming colours. This allows individual customisation of the appearance of the Skyline Edge Play island hood to suit both the individual mood and the ambience of the kitchen.





Skyline Edge Play Gesture control

Light and fan control

The Skyline Edge Play impresses with its innovative gesture control, which enables intuitive control of the basic functions. The island hood can be controlled touch-free and adjusted conveniently while cooking. Commands such as switching on the hob lighting or fan level adjustment are detected by the action sensor that is centrally positioned at the front of the Skyline Edge Play.





Lift function by gesture

The height of the Skyline Edge Play can be easily adjusted using the lift sensor, which is located on the right-hand side of the hood. The sensor is activated by a simple hand movement. After activation, the island hood can be conveniently controlled by hand to the desired height.

Skyline Edge Base island hood



Impressive all-rounder

The **Skyline Edge Base** island hood with lift function has an impressive appearance. Its solid glass hood body is enhanced by an all-round lighting strip. The island hood can be flexibly controlled via the remote control or the berbel+ app. Available in matt black, black or white, it integrates elegantly into any kitchen and creates an inviting atmosphere.





Skyline Edge Sound island hood



Soundful cooking experience

The **Skyline Edge Sound** island hood not only offers fresh air for the nose, but also a sonorous treat for the ears thanks to the integrated sound system. The innovative technology blends seamlessly with the aesthetics of the bonnet, while the berbel principle ensures efficient and permanently high grease separation. Individually adapted lighting is also provided by the LED hob lighting with dimmer function and adjustable colour temperature, which can be conveniently controlled by remote control.



Skyline Edge Light island hood

A luminous extractor hood

The powerful **Skyline Edge Light** ensures great air quality and a cosy kitchen atmosphere. Its distinctive design and large-surface effect lighting make it an attractive partner. The remote-controlled island hood floats down on cables to position itself over the hob. Fat particles don't stand a chance when faced with the berbel principle, and the particularly powerful recirculation filter reliably eliminates cooking odours.



Skyline Curve island hood



Heaps of character

The **Skyline Curve** is a perfect example of how a wide range of functions can be combined simply but really intelligently. Below the ceiling, the island hood takes on the role of a decorative light fitting, impressing onlookers with its soft design of stainless steel and glass. Activated by remote control, it moves down to hover elegantly above the hob, where it collects fat particles and cooking odours constantly and reliably. Using the berbel principle, of course!



Skyline Round island hood

A perfect radius

The **Skyline Round** is a functional marvel that floats practically weightlessly above the hob on cables. It creates a pleasant kitchen ambience with its upwards effect lighting and skilfully draws attention to the hob with integrated hob lighting. Thanks to its unique CenterFlow separation system, the island hood reliably eliminates all cooking and frying vapours. It's a real all-rounder.









Headroom hoods

Excellent efficiency at a very low noise level. What more could you want? How about award-winning design? Anyone can be a designer with the headroom hood Ergoline 2. Its glass panels are available in any custom colour, and the stainless steel body is available in matt black, too.

All headroom hoods are technically outstanding: they work without any fat filters. A special feature by berbel! It allows for unbroken extraction power and permanent efficiency.



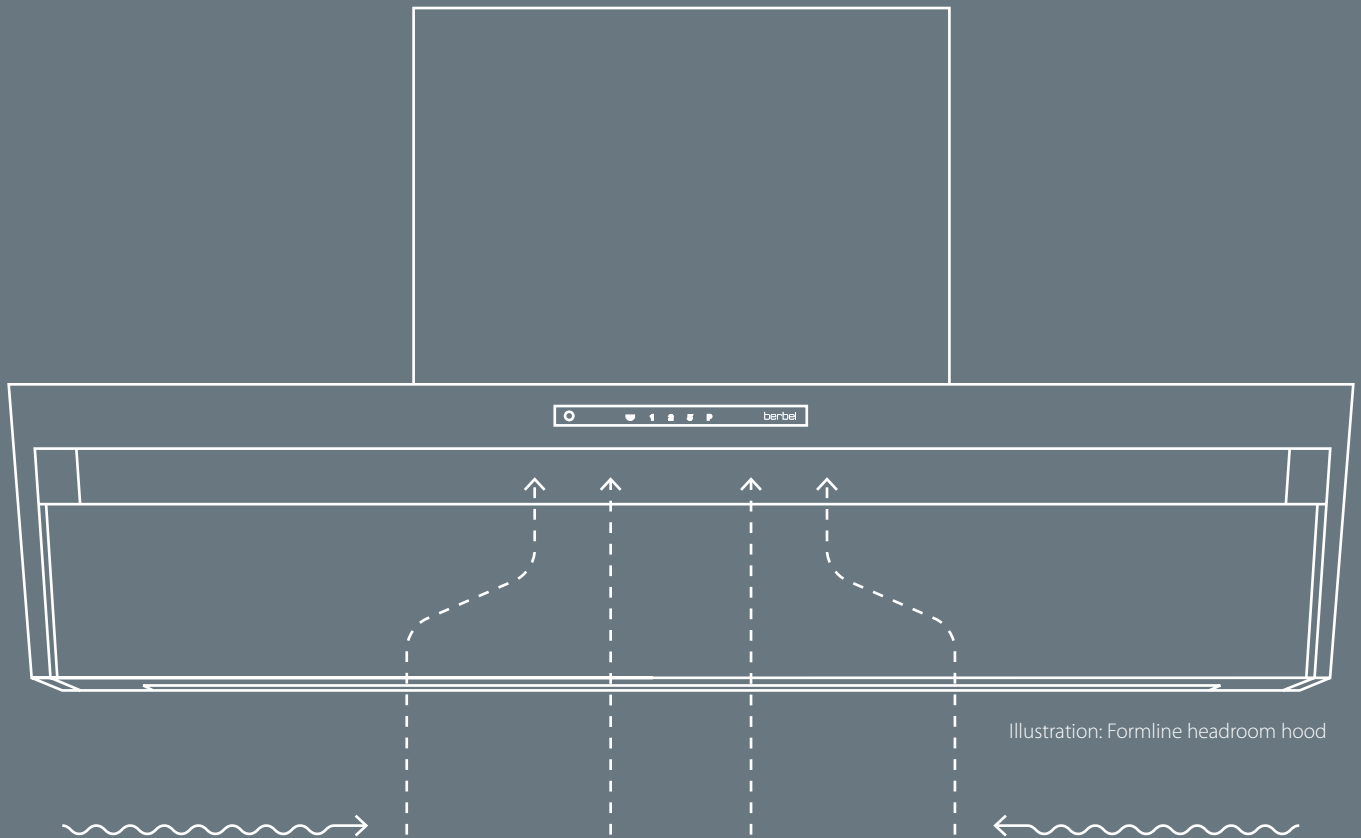

Functions: headroom hoods

Classy stainless steel

This is the material the entire hood body is made of. Sophisticated finishing with welded corners all around is guaranteed.

In the best light

Modern LED hob lighting provides for a balanced effect and pleasant illumination with adjustable colour temperature. The dimmer feature allows for even more atmospheric effects.

Recirculation today. Exhaust air tomorrow.

Ingenious EcoSwitch control allows for the extraction mode to be adjusted to the individual cooking endeavour or the time of year.

Flow controlled ventilation

berbel's patented BackFlow technology uses a sophisticated secondary ventilation system. The result: top-class efficiency! And no condensation on the outside of the hood.

Black is beautiful

This is demonstrated quite impressively by the version from the Black Edition. The body and shaft feature a matt black finish. A true eye-catcher – available for the models Formline and Ergoline 2.

Effortless cleaning

The whole bottom tray can be removed and wiped clean quickly. For even more effortless cleaning, it can also be placed in the dishwasher.

Ergoline 2 | Ergoline Base headroom hood

Head protection and a clear view

The headroom hoods in the Ergoline series impress with their extraordinary appearance. The fully equipped **Ergoline 2** boasts exceptional optics and numerous design options. Available in several colour variants and sizes, it can be adapted to any cooking situation. The entry-level **Ergoline Base** model offers stylish glass variants in white and black in widths of 80 cm and 90 cm. A dedicated recirculation hood that guarantees optimum technical performance despite a reduced range of functions. Both versions feature the patented BackFlow technology, which almost completely eliminates cooking and frying vapours and thus ensures a pleasant cooking experience.



Formline headroom hood



Elegance combined with functionality

The **Formline** headroom hood is completely robust, with a fully welded body made from stainless steel with high-quality workmanship. The colour temperature of the dimmable hob lighting can be adjusted from cold to warm white depending on your mood, to place everything in the best light possible. The Formline is available in five different widths, making it ideal for small and large kitchens alike. Also available in fashionable matt black.





Glassline headroom hood



For a gleaming look & feel

The **Glassline** headroom hood features rounded decorative glass and an elegantly concealed control panel which becomes visible only when touched. With patented BackFlow technology, it also happens to alleviate condensation on the glass surface. When the Glassline is not in use, its upwards rear lighting adds ambience to the kitchen



Smartline headroom hood

Smart and powerful

The flue-free **Smartline** headroom hood leaves plenty of room for modern kitchen planning. The carefully designed shape of the recirculation hood uses the berbel principle to ensure top-quality air cleaning when boiling, frying and steaming food. The Back-Flow technology reliably prevents the formation of condensation on the hood body. Available in three different colour variants. With a choice of an active carbon filter or a maintenance-free permalyt® filter.





Island hoods

Impressive performance thanks to the tried-and-tested berbel BackFlow technology for optimised vapour and odour capture. When it comes to their look, the island hoods don't fail to impress with their high-quality stainless steel finish and modern design. A true eye-catcher for any open plan kitchen.

Whether classic, elegant, or puristic - berbel island hoods turn any kitchen into a personal cooking studio. With the added benefit of atmospheric effect lighting.



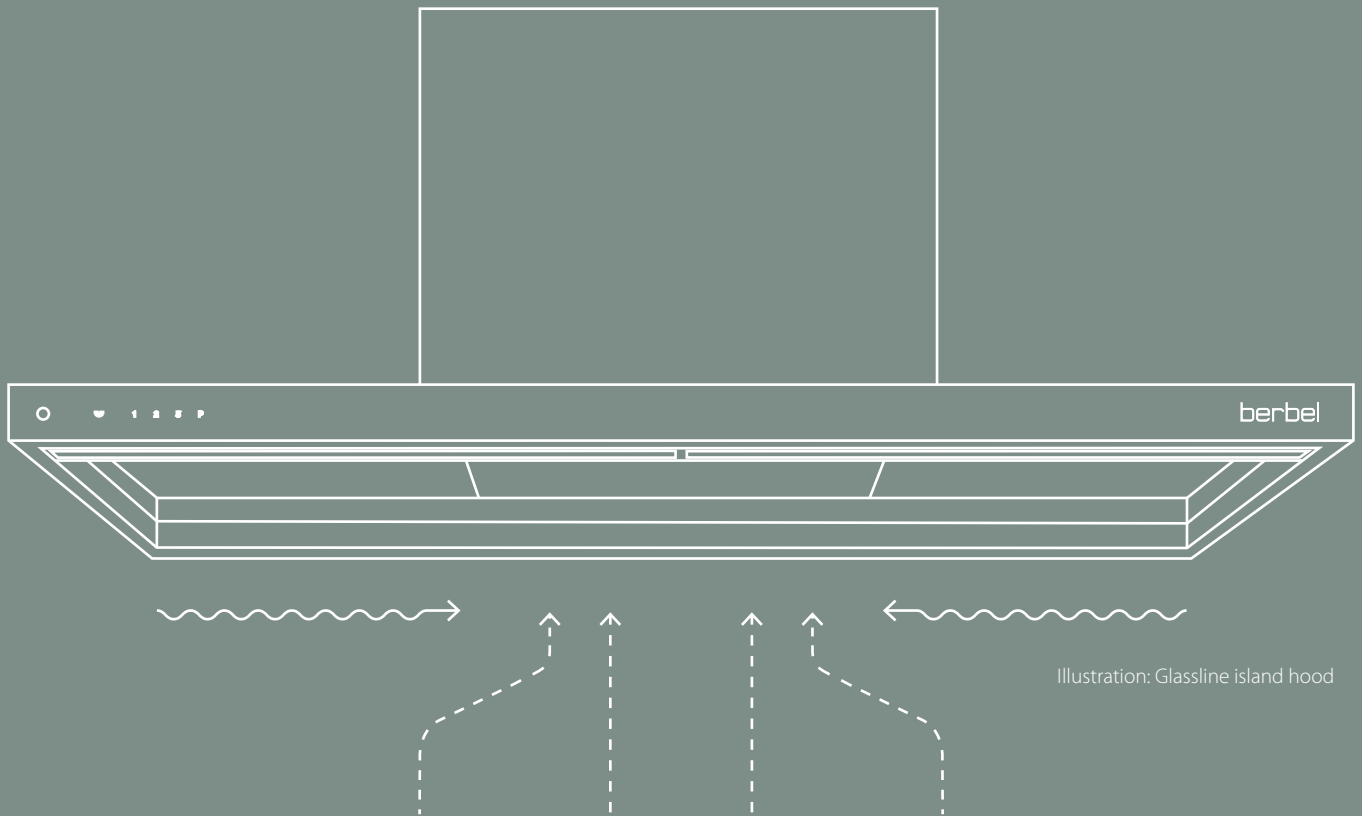

Functions: island hoods

Attractive shape

Classy, slim and ergonomic. The pure, stylish look blends effortlessly with any kitchen environment.

Tasteful lighting

Dimmable LED hob lighting with adjustable colour temperature* to fit any mood. Ranging from bright, clear work light through to cosy chill-out lighting.

Spotlessly clean

The entire separator unit/bottom tray can be removed and even cleaned in the dishwasher.

Flow-controlled ventilation

BackFlow technology*: a patented berbel speciality based on a sophisticated secondary ventilation system. The result: top-class efficiency!

Recirculation today. Exhaust air tomorrow.

Ingenious EcoSwitch control allows for the extraction mode to be adjusted to the individual cooking endeavour or the time of year.

*depending on the model

Ergoline island hood

A professional with a personality

The **Ergoline** island hood charmingly combines personality and function. Its exceptional shape guarantees carefree cooking enjoyment. All vapours and fat particles are sucked powerfully, quietly and efficiently into the island hood, thanks to the berbel principle. Easy cleaning of the collection trays ensures perfect hygiene, too.



Glassline island hood



A sleek silhouette

With its slim stainless steel body and black glass panels on both sides, the **Glassline** island hood is an eye-catcher in any kitchen. The integrated controls become visible only when touched and are really easy to use, even with damp fingers. Rising cooking and frying vapours are guided from the sides to the central extraction slot by a slight air current, ensuring top-quality air cleaning.





Blockline island hood



A sophisticated perfectionist

Thanks to its classic shape, top user-friendliness and intelligent air routing, the **Blockline** island hood is a perfectionist both visually and functionally. Exhaust or recirculation air? Not a problem with the berbel EcoSwitch! At the push of a button, it switches between exhaust mode, which directs odours and moisture outside, and recirculation mode, when the filtered, warm air remains in the room. The mode can be chosen as required for the current weather and cooking situation.



Smartline island hood

A charismatic powerhouse

The **Smartline** island hood from berbel features timeless stainless steel aesthetics and a distinctly slim body design. The Back-Flow technology guarantees the best-possible capture of rising cooking and frying vapours even at the edges of the hob. Cleaning the hood is also quick and easy. The entire separator unit can simply be removed and cleaned in a dishwasher. So convenient!









Wall-mounted hoods

The elegant wall-mounted stainless steel hood floats above the hob like a protective shield. Its clear lines enable it to blend with any furnishing style in a way that is both understated and eye-catching.

The atmospheric LED lighting shows off the operating principle: a gentle air current from the front, left and right guides rising vapours to the central extraction slot. This smart patented way to capture cooking vapours is called BackFlow technology and is only available from berbel. For you, this means that no condensation will form on or around the hood. So good!



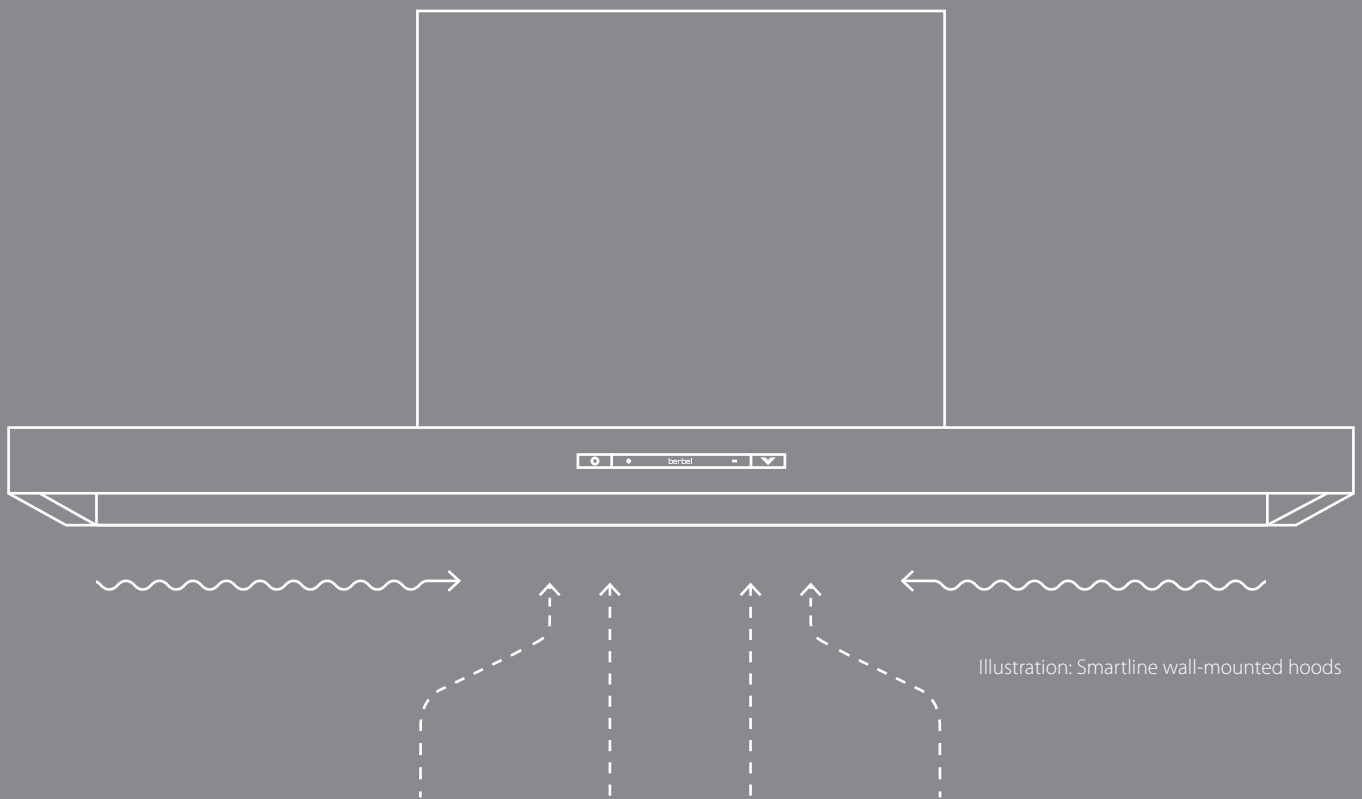

Functions: wall-mounted hoods

Attractive appearance

With their clear shapes and slim bodies, wall-mounted hoods by berbel look great in any kitchen.

In the best light

Balanced and pleasant hob lighting with modern LEDs. The dimmer feature allows for even more atmospheric effects.

Classy stainless steel

This is the material the entire hood body is made of. It goes without saying that it is finished to a very high standard.

Flow-controlled ventilation

berbel's patented BackFlow technology* uses a sophisticated secondary ventilation system. The result: top-class efficiency! And no condensation on the outside of the hood.

Effortless cleaning

The separator unit/bottom tray can be wiped clean quickly and the whole unit can be removed. For even more effortless cleaning, it can also be placed in the dishwasher.

Recirculation today. Exhaust air tomorrow.

Ingenious EcoSwitch control allows for the extraction mode to be adjusted to the individual cooking endeavour or the time of year.

*depending on the model

Glassline wall-mounted hoods

An elegant appearance

The **Glassline** wall-mounted hood fits in harmoniously with other kitchen units. Unnoticed yet highly efficient, it uses the berbel principle to filter fat particles and odours from the air. To ensure that all cooking vapours are captured, the BackFlow technology emits a slight air current at the sides and front. The control panel is concealed behind the glass front. It becomes visible only when touched and is easy to use.



Blockline wall-mounted hoods



A clear design vocabulary

Right on trend with the **Blockline** wall-mounted hood. The classic appearance and telescopic flue of this hood look great above the hob. The hood works reliably in exhaust mode. Thanks to the EcoSwitch control, it can also be switched from exhaust mode to recirculation mode to suit the current cooking situation or season of the year. The Blockline is available in three sizes, making it perfect in small and large kitchens.



Smartline wall-mounted hoods

Strong yet sparing

The **Smartline** wall-mounted hood casts its magic with a slim design and straight lines. Its body is made completely from stainless steel and features high-quality workmanship with a tidy appearance from below. A soft current of air from the front and sides guides rising vapours to the central intake point thanks to the BackFlow technology. The glare-free, warm-white LEDs provide perfect lighting for cooking.





Built-in hoods & fan units

If you like to cook opulently, you need a strong kitchen assistant to rely on. berbel's built-in hoods are the perfect partner for this. They remove fat and cooking vapours from the air, quickly and expediently. Equipped with BackFlow technology, the hoods reliably support the capture of rising cooking and frying vapours.

Modern design and innovative technology make built-in hoods by berbel powerful partners for modern kitchens.



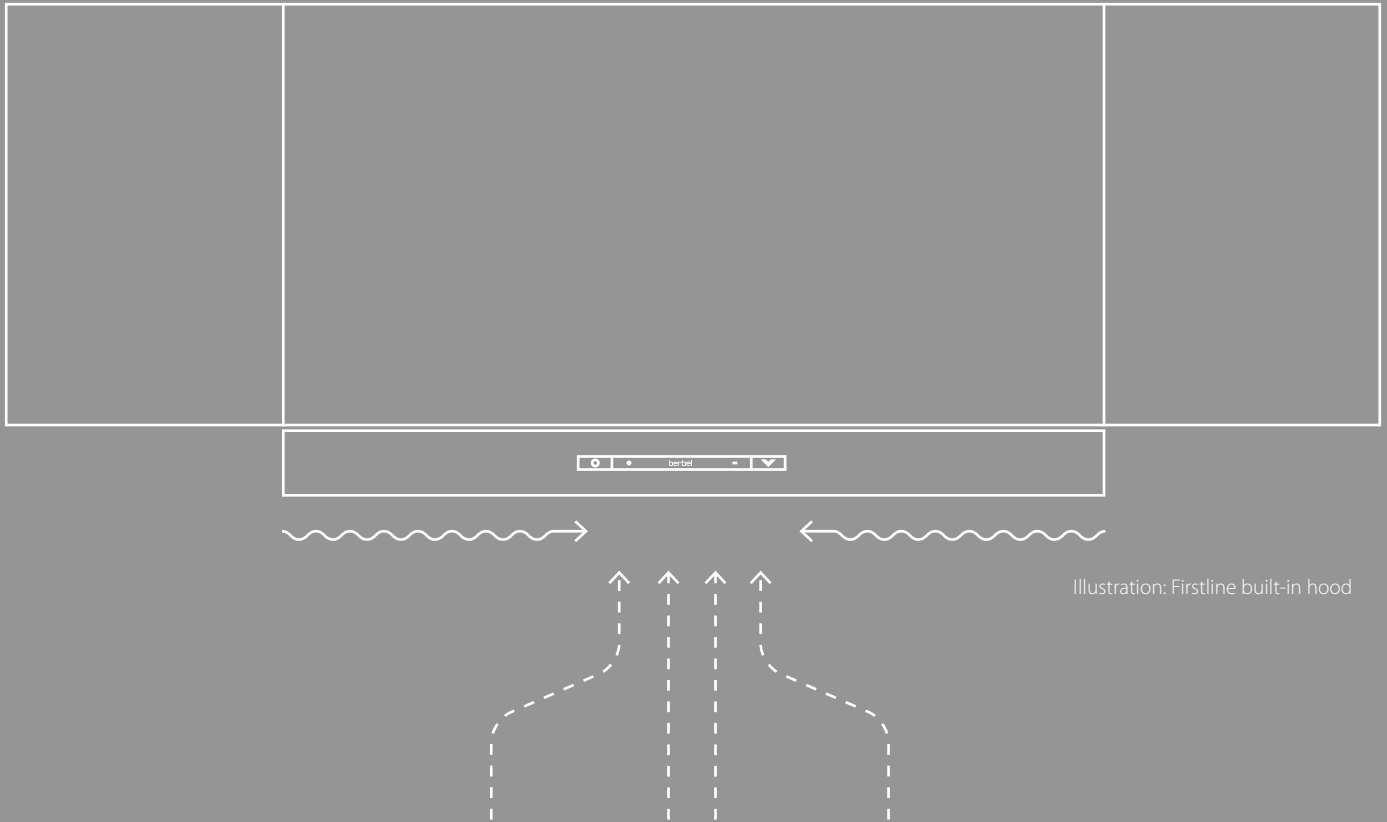

Illustration: Firstline built-in hood

Functions: built-in hoods

Impressive design

Featuring a coloured glass or stainless steel panel, the hoods are finished to a high standard and are so stylish, they effortlessly blend in with the kitchen's design.

In the best light

Modern LED hob lighting provides for a balanced effect and pleasant illumination. The dimmer feature allows for even more atmospheric effects.

Recirculation today. Exhaust air tomorrow.

Ingenious EcoSwitch control* allows for the extraction mode to be adjusted to the individual cooking endeavour.

Flow-controlled ventilation

berbel's patented BackFlow technology* uses a sophisticated secondary ventilation system. The result: top-class efficiency! Without any condensation forming on or around the hood.

Effortless cleaning

The bottom tray can be quickly wiped out and the whole unit can be removed. For even more effortless cleaning, it can also be placed in the dishwasher.

*depending on the model

Glassline built-in hood

An unobtrusive talent

The **Glassline** built-in hood reveals its strengths when it is switched on. The innovative control panel, which only becomes visible when touched, ensures this. Its flexibility is particularly impressive: Thanks to the EcoSwitch function, the Glassline can be used both as an exhaust hood and as a recirculation hood. When the built-in hood is not being used, it still attracts attention thanks to its elegant glass panel.



Firstline Touch built-in hood



Classic elegance

For compact kitchens, the **Firstline Touch** built-in hood is a real powerhouse. The modern sensor touch control system is surrounded by stainless steel with high-quality workmanship. The dazzle-free hob illumination creates optimum lighting conditions. Thanks to the EcoSwitch Function, the Firstline Touch can be used in exhaust mode or in recirculation mode. It works really quietly and efficiently.



Firstline built-in hood

An ambitious star

The **Firstline** built-in hood is a really useful helper in the kitchen. Its extendible screen and patented BackFlow technology make it a powerful partner. Fats and oils are collected in the collection tray. Then you simply fold it out, wipe it – and you're done! This entry-level built-in hood is particularly suitable for being fitted into existing kitchens. It's a functional miracle and can be operated in exhaust or recirculation mode.



Firstline Unseen built-in hood



A compact design

The **Firstline Unseen** built-in hood disappears into a top cupboard to live up to its name. The fan settings and hob lighting are controlled intuitively using the control pad. The light temperature can be adjusted continuously to create a particularly relaxed ambience. The BackFlow technology optimally supports the capture of cooking vapours and guarantees clean air.



Firstline fan unit

An invisible force

Thanks to its small installation depth, there's room for the **Firstline** fan unit in practically any top cupboard. Its flush design blends in perfectly with the kitchen ambience. The high-quality LEDs discreetly illuminate the hob and have an adjustable colour temperature. The fan unit eliminates fats and oils from the kitchen powerfully, quietly and efficiently using the berbel principle.



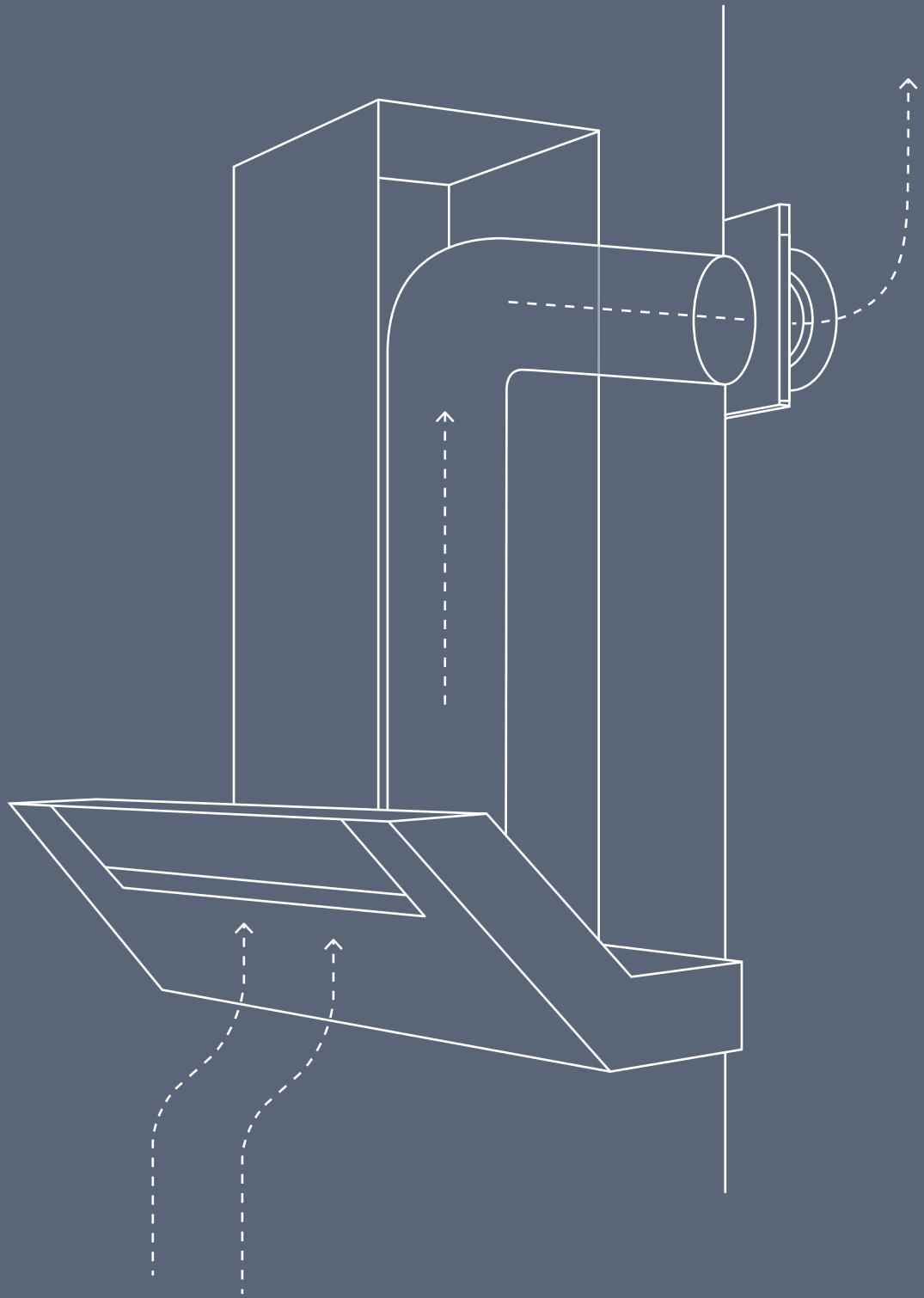



Exhaust air

Breathe deeply! An exhaust air system is the most effective way to remove stale kitchen air. Moisture, steam, smoke and odours are transported directly to the outside. Heat-insulated exhaust air routing is used to allow for an energy-efficient process.

Wall box

Energy-efficient exhaust system with a motor-operated exhaust pipe seal.

Suitable for use in low-energy buildings thanks to its BlowerDoor certificate.

Remote-controlled connection for berbel extraction systems or air-controlled for all other hoods.

High-quality workmanship, made entirely of stainless steel.

Diameter

125, 150 cm

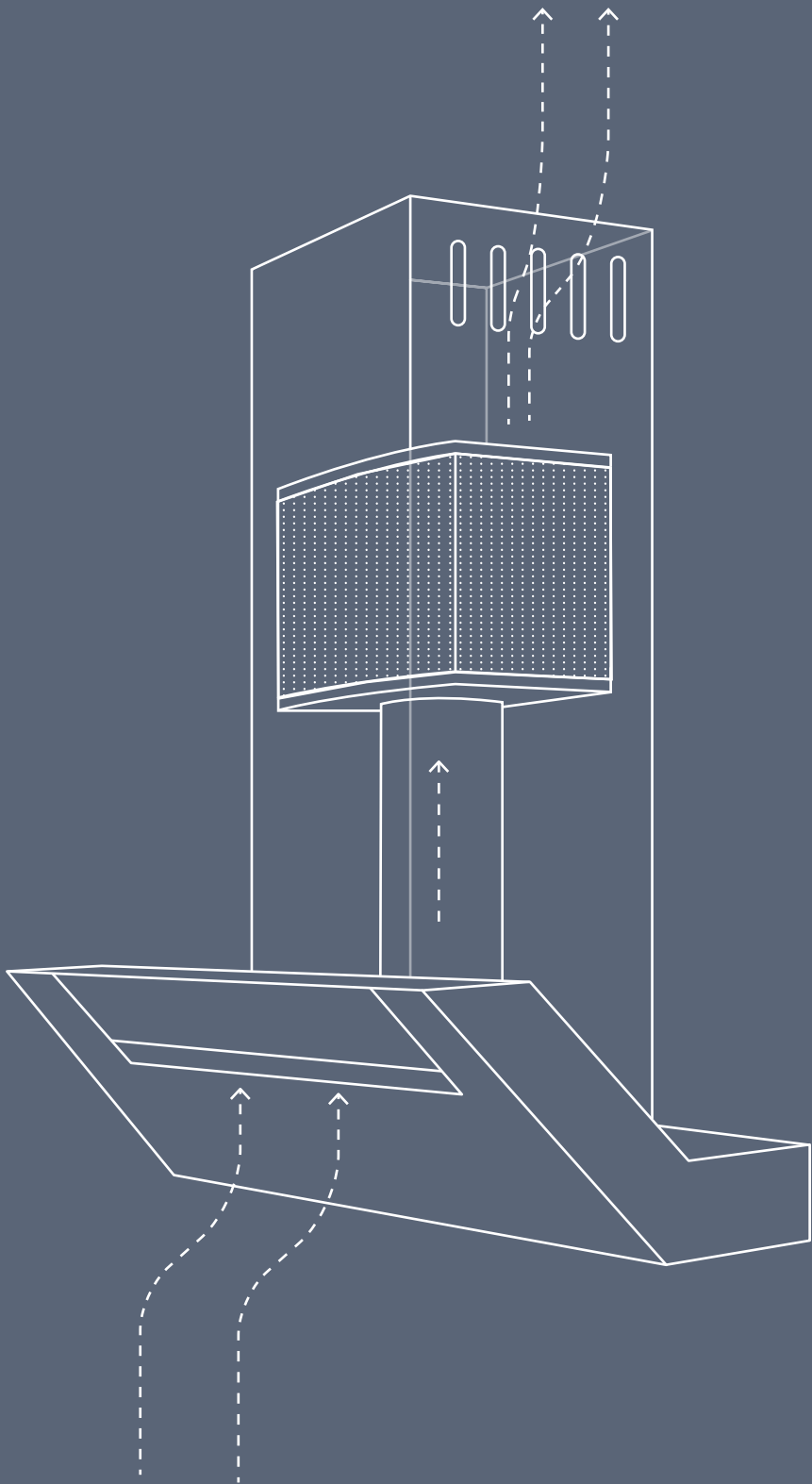



Recirculation | permalyt®

Looking for a solution that does not involve penetrating the wall?
No problem at all! berbel has perfected recirculation technology so it is on par with exhaust air technology. The active carbon in the filter binds up to 97 percent of all odours. There are two effective filter systems to choose from:

Recirculation filter

Extra big surface and an extra large amount of active carbon for up to 97 percent efficiency.

Fat-free and odour-neutral.

Low-cost refill packs for replacing the active carbon.

Variant: Special ProAktiv carbon for those who love to prepare fish.

permalyt® recirculation filter

A self-cleaning filter system.

Fully maintenance-free.

High-tech filter mat made of special active carbon granulate.

Innovative thermal catalysis neutralises up to 95 percent of odours and ensures clean air.



Permalyt® technology for hob
extractor fans



Permalyt® technology for extraction
systems

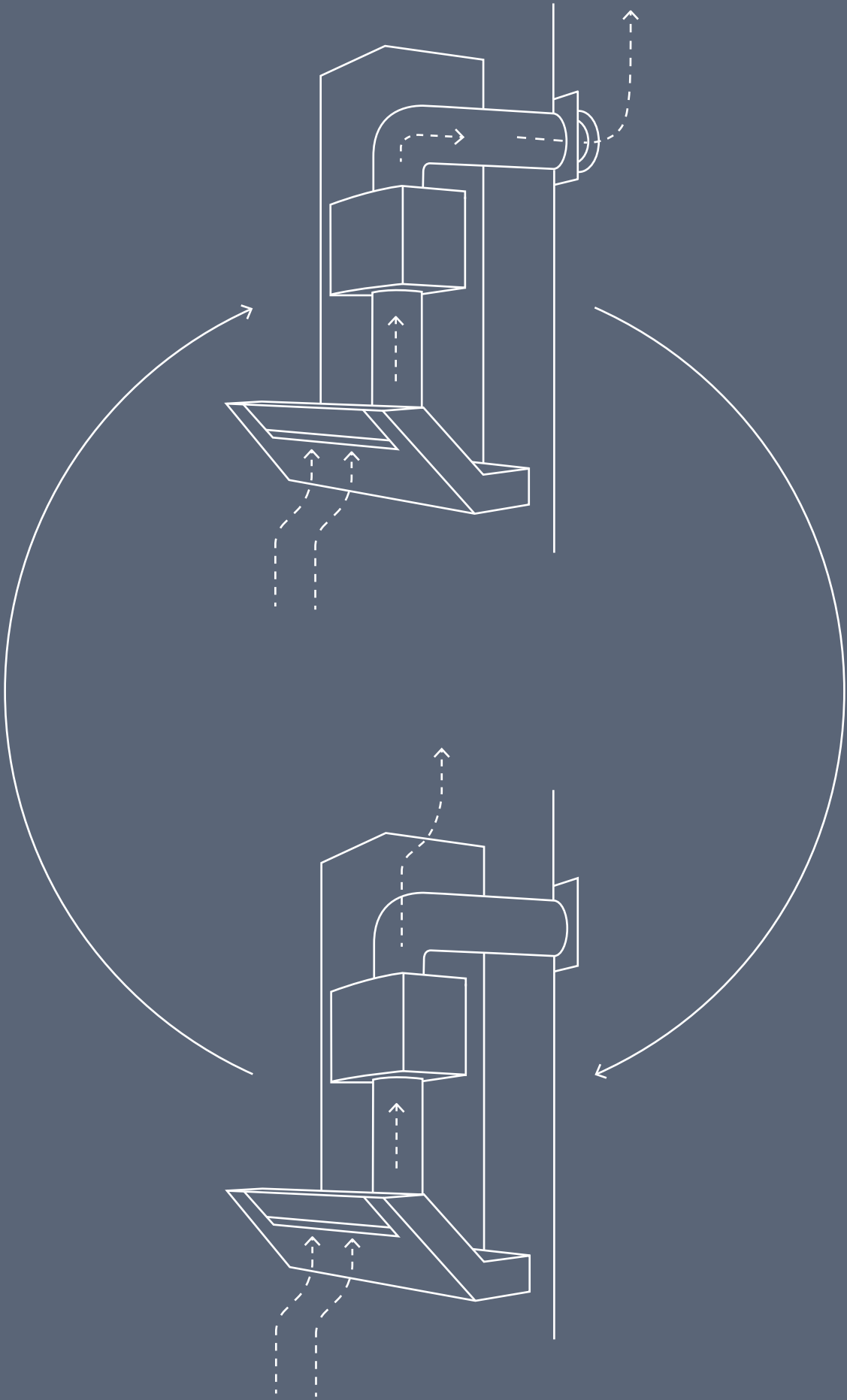



EcoSwitch

Exhaust air or recirculation mode? With berbel it is not necessary to make a definite choice. EcoSwitch allows for the best of both modes to be combined in a single device. Energy-efficient recirculation and powerful exhaust air mode that is used when large amounts of smoke or moisture must be extracted.

Components of the EcoSwitch system

- 1 EcoSwitch compatible berbel extractor hood.
 - 2 berbel wall box as a heat-insulated seal for the exhaust air route.
 - 3 berbel hybrid filter that binds up to 97 percent of odours in recirculation mode.
-

berbel EcoSwitch

Triple use hybrid filter

Use with EcoSwitch: The hybrid filter is responsible for cleaning the air in recirculation mode.

Use with recirculation mode: In combination with a recirculation filter, the intermediate hybrid filter reduces the physical air resistance of the recirculation filter above by increasing the filter surface. This increases the performance of the recirculation filter.

Use with exhaust air mode: The berbel hybrid filter acts as an overpressure valve. If the average diameter of the exhaust ducts on site is too small, the extractor hood will blow in air until the airflow is slowed down by the resulting resistance. The rest of the air returns to the room after being cleaned by the berbel hybrid filter.



BackFlow technology

With the berbel BackFlow technology, a sophisticated concept allows you to make the most of existing air flows. This prevents the formation of condensation on the decorative glass surfaces. At the same time, the targeted diversion of cooking and frying vapours increases the capture efficiency of the extraction system.

A modest feature with a big impact*

- ① The decorative panel is ventilated from bottom to top.
- ② On the rear of the extraction system, some of the air is conveyed back and over the glass front again.
- ③ The decorative surface is kept free from condensation as a result, and all cooking and frying vapours are routed to the intake point.

The result: particularly efficient capture of rising cooking and frying vapours and extremely effective air cleaning.

* The Ergoline 2 headroom hood is used as an example



Model overview

	→ Hob extractor fans			→ Hobs
	Downline Infinity	Downline Performance	Downline Compact	Induction hob Panorama Performance
Exhaust model	•	•	•	
Recirculation model	•	•	•	
permalyt® model	•	•	•	
Hybrid model				
Available widths in cm	90	83	83	90
Energy efficiency class ²	A+	A+	A+	
Number of cooking zones	4	4	4	4
Cooking zone dimensions in mm Zones 1 + 2 Zones 3 + 4	240 x 240 240 x 240 / 154 x 154	225 x 225 225 x 225	210 x 210 210 x 210	226 x 200 226 x 208
Movable Powermover	•	•		
Bridge function	•	•		•
Option to connect an external light source		•		
Flush/surface-mounted installation	•	•	•	•
Recirculation air routing using the outlet grid set	•	•	•	
Rotary knob control option	•			

→
Skyline island hoods

	Skyline Frame	Skyline Edge Play	Skyline Edge Base	Skyline Edge Sound	Skyline Edge Light	Skyline Curve	Skyline Round
Exhaust model							
Recirculation model	•	•	•	•	•	•	•
permylt® model	•	•	•	•	•	•	
Hybrid model (EcoSwitch)							
Available widths in cm	100 120 140 160	100 120	100 120	135	95 115	95 115	Ø 60
Colour finish ¹		black, white, silver grey, matt black, special colour	black, white, matt black	black, white, silver metallic, special colour	black, white, silver metallic, special colour	black, white, silver metallic, special colour	black, white
Energy efficiency class ²							
Gesture control		•					
Control option berbel+ app		•	•				
LED effect lighting "Motion lights"		•					
LED colour temperature control	•	•	•	•	•	•	•
Dimmable LEDs	•	•	•	•	•	•	•
Afterrun function for recirculation mode	•	•	•	•	•	•	•
Rec. distance from hob ³ in cm	65	65	65	65	65	65	65

¹ Glass decor in special colour available exclusively according to the RAL colour system

² No classification for recirculation hoods/hobs

³ Indicated for electric hobs; distance from gas hob > 65 cm



Model overview



Headroom hoods

	Ergoline 2	Ergoline Base	Formline	Glassline	Smartline
Exhaust model	•		•	•	
Recirculation model	•	•	•	•	•
permylt® model	•		•	•	•
Hybrid model (EcoSwitch)	•		•	•	
Available widths in cm	60 70 80 90 110 120	80 90	60 70 80 90 120	90	80 90
Colour finish ¹	black, white, silver metallic, matt black*, special colour	black, white	stainless steel, matt black*	black, white	mat black, mat white, grey metallic
Energy efficiency class ²	A		A A A B	A	
Pipe connection in mm	Ø 150		Ø 150	Ø 150	
BackFlow technology	•	•	•	•	•
Control option Connect 2.0	•		•	•	•
LED colour temperature control	•		•	•	
Dimmable LEDs	•		•	•	•
Afterrun function for recirculation mode	•	•	•	•	•
Rec. distance from hob ³ in cm	50	50	50	50	45

→
Island hoods

→
Wall-mounted hoods

	Ergoline	Glassline	Blockline	Smartline	Glassline	Blockline
Exhaust model	•	•	•	•	•	•
Recirculation model	•	•	•	•	•	•
permalyt® model	•	•	•	•	•	•
Hybrid model (EcoSwitch)	•	•	•		•	•
Available widths in cm	110	100	90 120	100	90	60 90 120
Colour finish ¹	black, white, silver metallic, special colour	stainless steel/black	stainless steel	stainless steel	stainless steel/black	stainless steel
Energy efficiency class ²	A	A	A+ A	A	A	A+ A+ A
Pipe connection in mm	Ø 150	Ø 150	Ø 150	Ø 150	Ø 150	Ø 150
BackFlow technology	•	•		•	•	
Control option Connect 2.0	•	•	•	•	•	•
LED colour temperature control	•	•			•	
Dimmable LEDs	•	•	•	•	•	•
Afterrun function for recirculation mode	•	•	•	•	•	•
Rec. distance from hob ³ in cm	70	70	65	70	70	65

¹ Glass decor in special colour available exclusively according to the RAL colour system

² No classification for recirculation hoods/hobs

³ Indicated for electric hobs; distance from gas hob > 65 cm

*Matt black version only BKH 80|90 EG-2 and BKH 90 FO



Model overview

	→ Wall-mounted hoods	→ Built-in hoods			
	Smartline	Glassline	Firstline Touch	Firstline	Firstline Unseen
Exhaust model	•	•	•	•	•
Recirculation model	•	•	•	•	•
permalyt® model	•	•	•	•	•
Hybrid model (EcoSwitch)		•	•		
Available widths in cm	90	60 90	60 80 90	60 80 90	60 90
Colour finish ¹	stainless steel	black, white	stainless steel	stainless steel	stainless steel
Energy efficiency class ²	A	A	A	A	B A
Pipe connection in mm	Ø 150	Ø 125	Ø 125	Ø 125	Ø 125
BackFlow technology	•	•	•	•	•
Control option Connect 2.0	•	•	•	•	•
LED colour temperature control		•	•		•
Dimmable LEDs	•	•	•		
Afterrun function for recirculation mode	•	•	•	•	•
Rec. distance from hob ³ in cm	65	55	55	55	55

→
Fan units

Firstline

Exhaust model	•
Recirculation model	•
permalyt® model	•
Hybrid model (EcoSwitch)	
Available widths in cm	60 90
Colour finish ¹	stainless steel
Energy efficiency class ²	A+
Pipe connection in mm	Ø 125
BackFlow technology	
Control option Connect 2.0	•
LED colour temperature control	•
Dimmable LEDs	
Afterrun function for recirculation mode	•
Rec. distance from hob ³ in cm	55

¹ Glass decor in special colour available exclusively according to the RAL colour system

² No classification for recirculation hoods/hobs

³ Indicated for electric hobs; distance from gas hob > 65 cm



Customer services

Outstanding products and outstanding service are standard at berbel.

Our in-house customer service team makes sure that everything is alright, even after the purchase. Our qualified employees will assist you with competent advice and expert knowledge. The berbel customer service team is available across Germany.

How to contact the berbel customer service team:
Monday to Thursday from 8:00 a.m. to 5:00 p.m.
and Friday from 8:00 a.m. to 4:30 p.m.

via our customer service hotline:
+49 (0) 5971 80809-0

or by sending an email to:
service@berbel.de

or online at:
www.berbel.de/service/serviceformular/



berbel Ablufttechnik GmbH

Sandkampstrasse 100
48432 Rheine, Germany

Tel.: +49(0)5971-80809-0
Fax: +49(0)5971-80809-10
www.berbel.uk
info@berbel.de

WEEE-Reg.-No.: 59614689
November 2023

berbel
living excellence.